



## KENTISH VERSUS SNOWY PLOVER: PHENOTYPIC AND GENETIC ANALYSES OF *CHARADRIUS ALEXANDRINUS* REVEAL DIVERGENCE OF EURASIAN AND AMERICAN SUBSPECIES

CLEMENS KÜPPER,<sup>1,2,4</sup> JAKOB AUGUSTIN,<sup>1,2,5</sup> ANDRÁS KOSZTOLÁNYI,<sup>1,6</sup> TERRY BURKE,<sup>2</sup>  
JORDI FIGUEROLA,<sup>3</sup> AND TAMÁS SZÉKELY<sup>1</sup>

<sup>1</sup>Department of Biology and Biochemistry, University of Bath, Bath BA2 7AY, United Kingdom;

<sup>2</sup>Natural Environmental Research Council Molecular Genetics Facility, Department of Animal and Plant Sciences, University of Sheffield, Sheffield S10 2TN, United Kingdom; and

<sup>3</sup>Department of Wetland Ecology, Estación Biológica de Doñana, CSIC, Avda. Americo Vespucio s/n, 41092 Sevilla, Spain

**ABSTRACT.**—Many shorebird species have widespread geographic distributions comprising several continents. Because shorebirds are excellent flyers and can migrate large distances, it is often unclear whether reproductive barriers between subspecies and populations from different continents exist. Kentish–Snowy Plovers (*Charadrius alexandrinus*) are cosmopolitan shorebirds. Whether the American and Eurasian subspecies—Snowy Plover and Kentish Plover, respectively—constitute a single species is the subject of a longstanding debate. We examined the divergence between American and Eurasian populations to reassess the current taxonomy by comparing genetic and phenotypic characters of the American subspecies *C. a. nivosus* and the Eurasian subspecies *C. a. alexandrinus* from seven populations. Genetic analyses revealed that American and Eurasian populations have strongly diverged, the Kentish Plover being more closely related to the White-fronted Plover (*C. marginatus*) than to the Snowy Plover. These results were consistent across all assessed nuclear markers (26 microsatellites and a partial CHD sequence) and two mitochondrial markers (ND3 and ATPase 6/8). Within subspecies, populations sampled across large geographic distances were not genetically differentiated (all  $F_{st} \leq 0.01$  and all  $\Phi_{st} \leq 0.06$ ), which suggests panmixia. Snowy Plovers differed morphologically from Kentish Plovers, having significantly shorter tarsi and wings. Chick plumage and calls also may serve as diagnostic characters to distinguish Snowy and Kentish plovers, although more data are needed to quantify these differences. Our combined results suggest that the taxonomic status of *C. alexandrinus* needs to be revised, and we propose that Kentish Plover and Snowy Plover be recognized as separate species: *C. alexandrinus* and *C. nivosus*, respectively. Received 15 September 2008, accepted 28 April 2009.

**Key words:** *Charadrius alexandrinus*, Kentish Plover, microsatellites, mitochondrial DNA, population differentiation, Snowy Plover.

### Análisis Fenotípicos y Genéticos de *Charadrius alexandrinus* Muestran Divergencia entre las Subespecies de Eurasia y América

**RESUMEN.**—Muchas especies de playeros tienen distribuciones amplias que incluyen continentes diferentes. Debido a que los playeros son excelentes voladores y tienen la capacidad de migrar largas distancias, muchas veces no está claro si existen barreras reproductivas entre poblaciones o subespecies de diferentes continentes. *Charadrius alexandrinus* es una especie cosmopolita. Hace mucho tiempo se ha debatido si las subespecies que se encuentran en las Américas y en Eurasia forman una sola especie. Para examinar su estado taxonómico, investigamos la divergencia entre las poblaciones de América y de Eurasia en características genéticas y fenotípicas de la subespecies *C. a. nivosus* (que se encuentra en América) y *C. a. alexandrinus* (que se encuentra en Eurasia) en siete poblaciones. Los análisis genéticos muestran que las poblaciones de América y Eurasia están marcadamente diferenciadas y que las poblaciones de Eurasia están más relacionadas con *C. marginatus* que con *C. a. nivosus*. Estos resultados genéticos fueron consistentes de acuerdo a todos los marcadores nucleares examinados (26 microsatélites y una parte del gen CHD) y a dos marcadores mitocondriales (ND3 y ATPasa 6/8). Dentro las subespecies, las poblaciones investigadas que estaban separadas por distancias grandes no estuvieron diferenciadas genéticamente (todos los valores de  $F_{st} \leq 0.01$  y de  $\Phi_{st} \leq 0.06$ ), lo que sugiere que existe panmixia. Morfológicamente, *C. a. nivosus* presentó tarsos y alas más cortos que *C. a. alexandrinus*. El plumaje de los polluelos y las llamadas también pueden servir como

<sup>4</sup>E-mail: [c.kupper@bath.ac.uk](mailto:c.kupper@bath.ac.uk)

<sup>5</sup>Present address: Department of Zoology, University of Gothenburg, Box 463, 405 30 Gothenburg, Sweden.

<sup>6</sup>Present address: Department of Ethology, Eötvös Loránd University, Pázmány Péter sétány 1/c., H-1117 Budapest, Hungary.

caracteres diagnósticos para diferenciar las dos poblaciones, aunque es necesario evaluar más datos para cuantificar las diferencias. Estos resultados sugieren que se necesita revisar la taxonomía de *C. alexandrinus*. Proponemos que las poblaciones de las Américas y de Eurasia sean reclasificadas como dos especies diferentes: *C. nivosus* y *C. alexandrinus*, respectivamente.

COSMOPOLITAN SPECIES HAVE widespread geographic distributions and can be found on most continents or in most oceans. Many cosmopolitan species are found among parasites, invertebrates, marine vertebrates, and small organisms (Klautau et al. 1999, Fenchel and Finlay 2004, Bleidorn et al. 2006). Terrestrial animals usually have smaller geographic ranges than marine animals, and fewer terrestrial than marine cosmopolitans have been identified (Gaston 2003).

Until recently, species often have been defined according to consistent morphological characters that are shared by a group of individuals but not between different groups ("morphospecies"). However, when molecular characters were included in their taxonomic evaluation, many of these morphospecies were found to consist of several cryptic species (i.e., species that are morphologically not distinguishable but belong to different evolutionary lineages; Klautau et al. 1999, Sáez and Lozano 2005, Bleidorn et al. 2006, Bickford et al. 2007). Cryptic species have been found across many different metazoan taxa. For example, in birds, 94 cryptic species complexes were identified between 1978 and 2006 (Pfenninger and Schwenk 2007).

Shorebirds, gulls, terns, and auks (Charadriiformes) harbor many species with outstanding migration abilities and widespread geographic distributions (del Hoyo et al. 1996, van de Kam et al. 2004). Among shorebirds, there are only two species with a cosmopolitan distribution that breed in both temperate and subtropical climate zones: Black-winged Stilt (*Himantopus himantopus*) and Kentish-Snowy Plover (*Charadrius alexandrinus*; Hayman et al. 1986, del Hoyo et al. 1996). The taxonomy and phylogeography of both species deserve special attention, given their widespread distribution and morphological differentiation into many subspecies and the implication of taxonomic status in conservation decisions.

Our understanding of the phylogeny and taxonomy of Charadriiformes has advanced rapidly since the introduction of new molecular and computational intensive methods (e.g., Ericson et al. 2003; Paton et al. 2003; Thomas et al. 2004a, b; Baker et al. 2007). However, there are still many unresolved questions regarding the exact phylogenetic relationships within and between most shorebird species. These unresolved relationships hamper our understanding of central problems in evolutionary biology that rely on a correct phylogeny, such as the evolution of mating and parental care systems (Székely and Reynolds 1995, Thomas and Székely 2005, Thomas et al. 2007).

The Kentish-Snowy Plover, first described by Linnaeus in 1758, breeds in temperate and subtropical regions of North America, South America, Africa, Europe, and Asia. Migratory Kentish Plovers also reach Australia during the non-breeding season (BirdLife International 2007). Recently, Kentish Plovers have attracted considerable attention in evolutionary and conservation biology because of their flexible breeding system (mating and parental care behavior, *sensu* Reynolds 1996) that varies both across and within populations (Lessells 1984, Warriner et al. 1986, Székely and Williams 1995, Amat et al. 1999, Kosztolányi et al. 2006, Székely et al. 2006) and because many populations are fragmented and declining (Page et al. 1995, Stroud et al. 2004).

The taxonomic classification of Kentish-Snowy Plover populations is still debated. The Kentish-Snowy Plover is considered by some authors to comprise a superspecies with White-fronted Plover (*C. marginatus*) and Red-capped Plover (*C. ruficapillus*) (Hayman et al. 1986, Sibley and Monroe 1990). Some authors also include the Javan Plover (*C. javanicus*) in this superspecies complex (Rittinghaus 1961, del Hoyo et al. 1996). Interestingly, the White-fronted Plover (the only other member of the superspecies whose breeding system has been studied) is considered monogamous (Lloyd 2008), whereas Kentish-Snowy Plovers are often polygynous and polyandrous (Lessells 1984, Warriner et al. 1986, Székely and Lessells 1993, Küpper et al. 2004). Six to 10 subspecies of Kentish-Snowy Plover are recognized, with most authors generally acknowledging six subspecies: *C. a. nivosus*, *C. a. tenuirostris*, and *C. a. occidentalis* inhabit North America and South America and are commonly called Snowy Plovers. The other three acknowledged subspecies, *C. a. alexandrinus*, *C. a. dealbatus*, and *C. a. seebohmi*, breed in Eurasia (Rittinghaus 1961, Cramp 1983, del Hoyo et al. 1996) and are commonly called Kentish Plovers. The classification of Snowy Plovers into three subspecies was recently supported by mitochondrial and microsatellite analyses (Funk et al. 2007).

Whether the American and Eurasian subspecies belong to the same species has been the subject of an ongoing debate. The Snowy Plover was originally considered a separate species (described as *Aegialitis nivosa* by Cassin 1858; cited in Oberholser 1922). Later, the three Snowy Plover subspecies were merged with the Kentish Plover subspecies, because the differences in adult plumage were not consistent (Oberholser 1922). The latter proposition was accepted by Monroe and Sibley (1993), although Sibley and Monroe (1990) commented that the three American subspecies should be separated from the three Eurasian subspecies.

We investigated population differentiation using genetic and phenotypic characters of American and Eurasian populations of *C. alexandrinus* to evaluate their current taxonomic status. First, we examined molecular characters of populations of Snowy and Kentish plovers and compared them with molecular characters of White-fronted Plover and Rufous-chested Dotterel (*C. modestus*). Second, we compared quantitative (body mass, tarsus, and wing length) and qualitative (chick plumage and calls) phenotypic characters between populations of Kentish and Snowy plovers.

## METHODS

*DNA sample collection and preparation.*—We obtained DNA samples from seven populations (Fig. 1), including four Eurasian populations (Doñana, Spain; Tuzla, Turkey; Al Wathba, United Arab Emirates [UAE]; and Kujalnik, Ukraine), two American populations (Ceuta, Mexico; and Great Salt Lake, Utah), and one population of White-fronted Plovers on the west coast of Madagascar.

The White-fronted Plover samples were included as an outgroup for mitochondrial and nuclear marker analyses to evaluate the magnitude of the differences between Kentish and Snowy plovers. Four samples of the Rufous-chested Dotterel breeding in

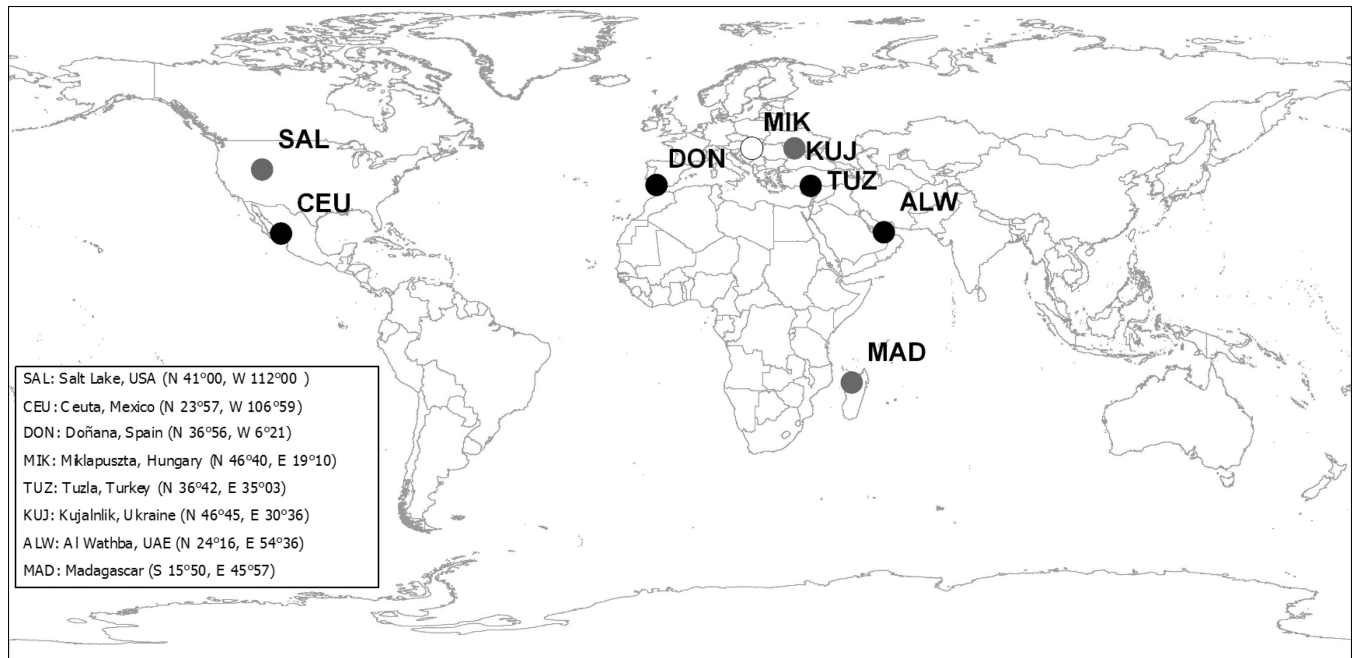

FIG. 1. Sampling map for breeding populations of Kentish Plover (Eurasia), Snowy Plover (America), and White-fronted Plover (Africa). Black circles refer to locations where both DNA and biometric data were obtained, gray circles refer to locations where only DNA was sampled, and the open circle indicates that only biometric measurements were taken.

the Falkland Islands were included as a second, more distantly related, outgroup in the mitochondrial analyses.

To obtain DNA samples, adult plovers were trapped on the nest during incubation using funnel traps (Székely et al. 2008). We obtained 25–50  $\mu$ L of blood from the brachial vein and stored the blood either in Queen's lysis buffer (Seutin et al. 1991) or absolute ethanol until extraction. All samples were collected between 1997 and 2006 (see Blomqvist et al. 2002, Küpper et al. 2004).

DNA was extracted using the ammonium acetate (Nicholls et al. 2000), salt acetate (Bruford et al. 1998), or an adapted phenol–chloroform method (Krokene et al. 1996). All DNA samples were extracted by C.K. and J.A., except for samples from Great Salt Lake, which were kindly provided by Tom Mullins and Susan Haig (U.S. Geological Survey Forest and Rangeland Ecosystem Science Center, Corvallis, Oregon). Extracted DNA was visualized on a 0.8% agarose gel stained with SYBRsafe (Invitrogen, Carlsbad, California) to assess DNA quality. DNA quantity was estimated by measuring the optical density of samples at 260 nm using a Fluostar Optima fluorimeter (BMG Labtech, Offenburg, Germany).

**Mitochondrial analyses.**—We amplified two mitochondrial markers: an approximately 400-base-pair (bp) NADH dehydrogenase subunit 3 fragment (ND3, using the L10755 and H11151 primers; Chesser 1999) and a 1.2-kilo-base-pair sequence including partial fragments of the ATPase subunit 6/8 genes (ATPase 6/8, using the CO2GQL and CO3HMH primers; Eberhard and Birmingham 2004).

We amplified fragments using 20- $\mu$ L polymerase chain reactions (PCRs) that contained 20 ng of DNA and 0.5 units of Taq DNA polymerase (BioLine) in the manufacturer's buffer with a

concentration of 1.0  $\mu$ M of each primer, 2.0  $\mu$ M  $MgCl_2$ , and 0.20 mM of each dNTP. The PCRs were performed on a thermal cycler (model PTC DNA engine; MJ Research, Waltham, Massachusetts) using the following program: one cycle of 3 min at 94°C followed by 35 cycles of 94°C for 30 s, annealing temperature of 55°C for 30 s, 72°C for 30 s, and a final extension cycle of 10 min at 72°C. To check for amplification success, we visualized 5  $\mu$ L of each PCR product on a 2% agarose gel stained with SYBRsafe (Invitrogen).

Successful PCR products were precipitated with ethanol and sequenced using Big Dye Terminator Cycle chemistry on ABI 3730 capillary DNA automated sequencers. Rufous-chested Dotterel samples and plover samples from Doñana were sequenced at the Natural Environmental Research Council (NERC) Biomolecular Analysis Facility (NBAF) at the University of Sheffield, whereas all other samples were sequenced at the NERC NBAF at the University of Edinburgh. The location of the sequencing did not affect the results, because the same haplotypes were found among individuals sequenced in either Sheffield or Edinburgh (see below). Sequences were edited using CODONCODE ALIGNER, version 2.0.0 beta 7 (CodonCode, Dedham, Massachusetts). Only partial sequences with both forward and reverse strands available were used in subsequent analyses. In total, a 386-bp partial sequence of the ND3 gene and a 399-bp sequence of the ATPase 6/8 genes for each of 53 individuals across the seven populations were available for the subsequent analysis (for frequency distribution, see Table 1). Sequences were aligned using the CLUSTALW algorithm implemented in CODONCODE ALIGNER.

The use of avian blood as a DNA source can lead to amplification of nuclear pseudogenes. We tested amplification of

TABLE 1. Summary of genetic variation indices of ND3 and ATPase 6/8 markers for two Snowy Plover, one White-fronted Plover, and four Kentish Plover populations. The two mtDNA markers combined covered a total of 785 bp mtDNA sequence.

Population	<i>n</i>	ATPase 6/8			ND3			Combined		
		<i>h</i>	<i>s</i>	$\pi$	<i>h</i>	<i>s</i>	$\pi$	<i>h</i>	<i>s</i>	$\pi$
Snowy Plover										
Ceuta, Mexico	8	0.00	0	0.00	0.00	0	0.00	0.00	0	0
Salt Lake, Utah	5	0.40	1	0.40	0.00	0	0.00	0.40	1	0.40
White-fronted Plover										
West coast, Madagascar	4	0.00	0	0.00	0.67	1	0.67	0.67	1	0.67
Kentish Plover										
Al Wathba, United Arab Emirates	8	0.86	3	1.11	0.25	1	0.25	0.86	4	1.36
Doñana, Spain	9	0.42	2	0.44	0.22	1	0.22	0.58	3	0.67
Tuzla, Turkey	9	0.81	2	0.83	0.47	1	0.47	0.92	3	1.33
Kujalnik, Ukraine	10	0.64	3	0.76	0.53	1	0.53	0.87	4	1.29

Note: ATPase 6/8 = ATPase subunit 6 and partial ATPase subunit 8; ND3 = partial ND3 gene for NADH dehydrogenase subunit 3; *n* = number of genotyped individuals; *h* = haplotype diversity; *s* = number of polymorphic sites; and  $\pi$  = nucleotide diversity.

the targeted mitochondrial regions by checking the translated amino acid sequence for stop codons, which we assumed to occur in nuclear pseudogenes. For genes, we translated the coding mitochondrial sequences into peptide sequences using the EBI-Transeq tool (see Acknowledgments). Peptide sequences of ND3 and ATPase 6/8 did not show any unexpected stop codons, which increased our confidence that we amplified the mitochondrial genes. Mitochondrial sequences were deposited in the European Molecular Biology Laboratory database under accession numbers AM941552–657 and FM995615–622.

*Phylogenetic analyses using mitochondrial markers.*—Before the phylogenetic and population genetic analysis, we tested sequence homogeneity within the concatenated sequences using the partition homogeneity test with 100 replications in PAUP\*, version 4.0b10 (Swofford 2000). The test results ( $P = 0.47$ ) did not indicate any significant conflicts. Therefore, we used the concatenated sequence for parsimony and population genetic analyses.

For the parsimony analyses, a heuristic search with 300 random-addition sequence replicates and tree bisection and reconnection (TBR) branch swapping was performed in PAUP\*. Nodal support was assessed through nonparametric bootstrap analysis using 1,000 bootstrap replicates, each with 100 random-addition sequence replicates and TBR branch swapping. For the Bayesian analysis, the most appropriate model of sequence evolution was selected using Akaike's information criterion (Akaike 1974) in MRMODELTEST, version 2.2 (Nylander 2004). The Bayesian analysis was conducted using MRBAYES, version 3.1, with data partitioned according to the different mtDNA markers (Huelsenbeck and Ronquist 2001). The default settings (two Markov chains at four different temperatures) were used. Markov chains were sampled every 100 generations and run for 5 million generations. Trees were drawn using TREEVIEW, version 1.6.6 (Page 1996).

*Population genetic analyses using mitochondrial markers.*—Analyses were performed using ARLEQUIN, version 3.1 (Excoffier et al. 2005). Genetic variation within populations was estimated using several diversity statistics, including haplotype diversity (*h*), number of polymorphic sites (*s*), and nucleotide diversity ( $\pi$ ). Corrected mean percentage sequence divergences between populations and the three major groups (Kentish Plover, Snowy Plover, and

White-fronted Plover) were calculated. Genetic divergence among populations was estimated by  $\Phi$  statistics and analysis of molecular variance (AMOVA; Excoffier et al. 1992), which takes into account the number of mutations between haplotypes. A permutation test with 100 randomly generated  $\Phi_{st}$  values was used to test the probability of observed  $\Phi_{st}$  values arising by chance. Pairwise  $\Phi_{st}$  values were calculated among all seven populations and among the putative three major groups. Significance levels were adjusted using the sequential Bonferroni method (Rice 1989). We used AMOVAs to compare the variance components explained by the major groups, populations, and individuals. One thousand random permutations were used to test for the significance of variance components.

*Nuclear markers.*—Fragment length differences in nuclear markers were examined in 166 individuals from the seven plover populations using a sex-specific marker located in the chromohelicase DNA binding protein (CHD) gene and 26 autosomal microsatellite markers. In many birds, the sexes can be distinguished according to the specific product sizes of an amplified CHD PCR product (Griffiths et al. 1998). Product sizes of CHD fragments are not only sex-chromosome-specific, but often also species-specific (cf. D. A. Dawson's bird sex-marker web page; see Acknowledgments). To examine whether Kentish, Snowy, and White-fronted plovers differ in the W- or Z-CHD product size, we amplified a partial sequence of the CHD gene using NED-labeled sexing primers (P2/P8 primers; Griffiths et al. 1998).

We chose 26 microsatellite markers that could be arranged in multiplex PCRs to examine group and population differentiation. All 21 Calyx primer pairs (sequences in Küpper et al. 2007) were designed from microsatellite loci isolated in Kentish Plovers. Additionally, four primer sets developed for Snowy Plover microsatellite loci (C201, C203–C205; Funk et al. 2007) and one primer set developed for a Barn Swallow locus (*Hirundo rustica*) (Hru2; Primmer et al. 1995) were used.

Each sample was run in four multiplex PCRs (MR 1–4) containing different combinations of fluorescently labeled primers (MR 1: Calyx-02, -04, -05, -08, -18, -19, -23, -24, -39, -43, -45, and P2/P8 primer set; MR 2: Calyx-01, -11, -12, -14, -22, -28, and -37; MR3: Calyx-10, -32, -35, C201, and C203; MR4: C204, C205, and Hru2). MRs with a total volume of 10  $\mu$ L contained 8  $\mu$ L mastermix

solution (Qiagen, Valencia, California), ~2  $\mu$ M of the primer mix, and 10 ng DNA. Relative primer concentrations were optimized to obtain similar peak sizes across different primer sets in the fragment analysis. MRs were performed in a thermal cycler (MJ Research model PTC DNA engine) according to the multiplex kit manufacturer's default protocol: the program started with a 15-min activation cycle at 95°C followed by 35 cycles of 94°C for 30 s, annealing temperature (MR 1: 57°C, MR 2: 62°C, MR 3 and 4: 60°C) for 90 s, and 90 s at 72°C. The program finished with a 10-min extension cycle at 72°C. A fraction of the MR products was loaded onto the ABI 3730, and allele sizes were assigned using GENEMAPPER, version 3.7 (Applied Biosystems, Foster City, California).

Hardy-Weinberg equilibrium and linkage disequilibrium between markers were tested in GENEPOP, version 3.3 (Raymond and Rousset 1995), using the Kentish Plover samples from Tuzla ( $n = 30$  individuals) for which most markers had been developed (Küpper et al. 2007). The sequential Bonferroni method was applied to correct for multiple testing.

*Estimating genetic diversity with microsatellites.*—Heterozygosity corrected for sample size (Nei 1978) was calculated in SPAGeDi, version 1.2 (Hardy and Vekemans 2002). Heterozygosities were compared using a nonparametric Kruskal-Wallis test followed by a *post-hoc* Wilcoxon rank-sum test with the sequential Bonferroni correction to identify population pairs that differed significantly.

*Estimating genetic differentiation with microsatellites.*—Genetic divergence was assessed by first calculating pairwise  $F_{st}$  values between populations and major groups and, second, by an AMOVA analysis using ARLEQUIN. As with mtDNA, the significance of  $F_{st}$  values was tested using a permutation test with 100 random permutations.

Two Bayesian clustering approaches were used to examine population differentiation. First, we tested differentiation with STRUCTURE, version 2.1 (Pritchard et al. 2000), to estimate the number of clusters ( $K$ ) and to assign individuals to one or more of these clusters. We used the admixture model, which assigns a proportion of each individual's genome to each population, assuming gene flow among populations. The likelihood for each number of clusters, ranging from  $K = 1$  (complete panmixia) to  $K = 7$  (maximum divergence), was calculated assuming correlated allele frequencies. Ten independent simulations with a burn-in length of 1,000,000 and a run length of 1,000,000 generations were conducted for each  $K$ , and we evaluated the assignment probabilities, log likelihood, and  $\Delta K$  (Evanno et al. 2005) to determine the optimal number of clusters. Second, we used BAPS, version 5 (Corander et al. 2003), to run five iterations of a population mixture analysis. The program first calculates the likelihood for the number of clusters using individuals in the mixture analysis. This is followed by a population admixture analysis to assign genotypes to the different clusters with  $P \geq 0.95$ .

*Biometry of adults and chicks.*—We collected data on tarsus length, wing length, and body mass of adult breeders, and tarsus length and body mass of chicks. Snowy Plovers were measured at Ceuta (collected in 2006–2007), whereas Kentish Plovers were measured at Miklapusztá (Hungary, collected in 1992–1994), Tuzla (collected in 1997–1999), Doñana (collected in 2004 and 2006), and Al Wathba (collected in 2005–2006). We measured tarsus length to the nearest 0.1 mm and wing length to the nearest

millimeter. If measurements of both limbs were available, we used their mean in the analysis. Body mass was measured to the nearest 0.1 g using Pesola spring balances.

We randomly selected 40 breeding males and 40 breeding females from each population and used two-way analyses of variance (ANOVAs) with population and sex as factors to examine biometric differences between plover populations. Nonsignificant interactions were removed from the final model. To compare biometrics specifically between Snowy and Kentish plovers, we used contrast analysis in which we contrasted, *a priori*, measurements from Snowy Plovers (Ceuta) with measurements from Kentish Plovers (Al Wathba, Tuzla, Doñana, and Miklapusztá). If the population means tested by the ANOVAs differed significantly, we further examined the differences by *post-hoc* Tukey tests. Similarly, we compared the tarsus lengths and body masses of nine randomly selected chicks (each of a different family) that had been measured on the day of hatching, using one-way ANOVAs with the contrast methods outlined above. For statistical analyses, we used R, version 2.4.1 (R Development Core Team 2006).

*Plumage and calls.*—Chick plumage and adult calls were sampled in different populations. However, small sample sizes prevented quantitative analyses, and potentially diagnostic differences are presented in the Appendix.

## RESULTS

*Mitochondrial markers.*—Among the 785 characters of the concatenated mtDNA sequence, 136 bp were informative for the parsimony analysis. The mean base frequencies of the total sequence were as follows: adenosine, 30.4%; cytosine, 23.5%; guanine, 18.9%; and thymine, 27.2%. Eighteen distinct haplotypes were found among 53 plovers. Two haplotypes belonged to 13 sequenced Snowy Plovers, two haplotypes were present in four White-fronted Plovers, and 14 haplotypes were found among 36 Kentish Plovers. Haplotypes were shared among individuals of different populations within, but not among, the three major groups.

*Phylogenetic analyses using mitochondrial DNA.*—Parsimony analysis generated 10 maximum parsimonious trees with 153 steps. Bootstrap analysis provided 100% nodal support for the three taxonomic groups, Kentish Plover, Snowy Plover, and White-fronted Plover (Fig. 2).

The most appropriate model for sequence evolution was the HKY+I model (Hasegawa et al. 1985), so this was chosen for the Bayesian mtDNA analysis. In this analysis, likelihood values converged after ~50,000 generations. Before constructing the tree, we removed a conservative burn-in period of 1,250,000 generations (25%) according to the MRBAYES manual. The Bayesian tree showed the same highly supported branches as the parsimony tree (Fig. 2). All Snowy Plover mitochondrial sequences segregated on a separate branch from Kentish and White-fronted plovers (nodal support  $\geq 95$ ). Intrataxon groupings were less well supported, with only one group of White-fronted Plovers showing credibility values of 92, whereas all other groups had credibility values  $< 75$ , and clusters were not associated with geography.

*Genetic diversity estimated from mitochondrial DNA.*—Mitochondrial diversity was low in Snowy Plover populations (Table 1). Across 13 individuals, we found only a single polymorphic site over the mitochondrial sequence, whereas we found, on average, three

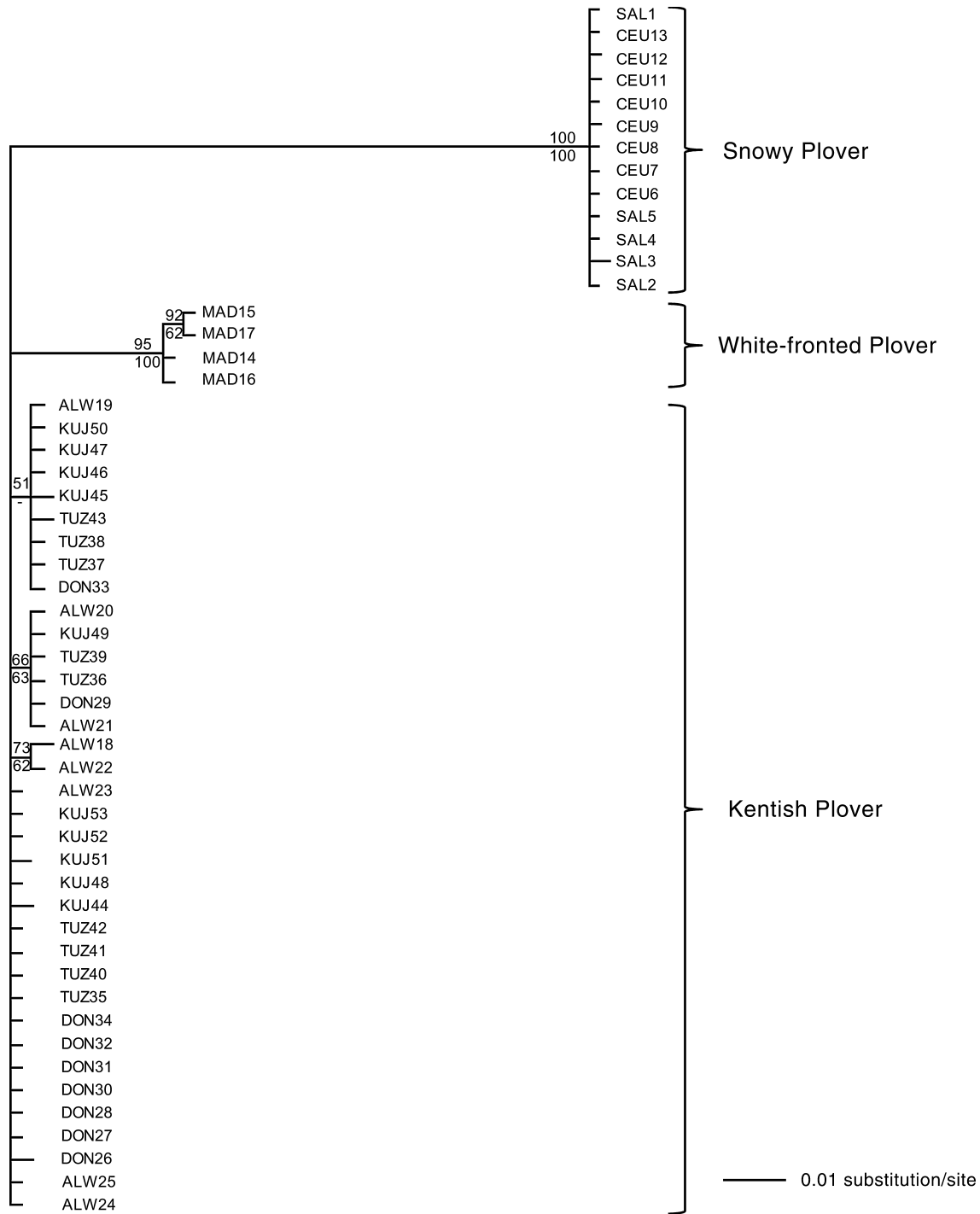

FIG. 2. Phylogenetic tree generated with MRBAYES for mitochondrial haplotypes of 53 White-fronted, Snowy, and Kentish plovers. The three major groups are indicated by brackets. Nodal support values for each lineage are given for Bayesian inference (above branch) and parsimony analysis (below branch). Rufous-chested Dotterel (not shown) served as outgroup.

or four polymorphic sites in each Kentish Plover population with  $\leq 10$  individuals sampled in each population (Table 1).

*Genetic differentiation estimated from mitochondrial DNA.*—The net sequence differences of mtDNA markers differed

significantly among Snowy, White-fronted, and Kentish plovers ( $P < 0.001$ ). Kentish and Snowy plovers (average net sequence difference: 6.1%) differed more than Kentish and White-fronted plovers (2.1%), whereas the largest difference was found between

TABLE 2. Values of  $\Phi_{st}$  for mitochondrial markers (above diagonal) and  $F_{st}$  values for 21 unlinked microsatellite markers (below diagonal) among seven breeding populations of Snowy Plover (Ceuta and Salt Lake), White-fronted Plover (Madagascar), and Kentish Plover (Al Wathba, Doñana, Tuzla, and Kujalnik). The  $\Phi_{st}$  and  $F_{st}$  values were tested for significance using 100 random permutations, and sequential Bonferroni correction was applied to account for multiple tests. Significant values with  $P < 0.001$  are in bold; remaining values are all nonsignificant.

Populations	Ceuta	Salt Lake	Madagascar	Al Wathba	Doñana	Tuzla	Kujalnik
Ceuta	—	0.02	<b>0.98</b>	<b>0.96</b>	<b>0.95</b>	<b>0.97</b>	<b>0.96</b>
Salt Lake	-0.01	—	<b>0.98</b>	<b>0.96</b>	<b>0.95</b>	<b>0.97</b>	<b>0.95</b>
Madagascar	<b>0.61</b>	<b>0.63</b>	—	<b>0.92</b>	<b>0.90</b>	<b>0.94</b>	<b>0.91</b>
Al Wathba	<b>0.36</b>	<b>0.28</b>	<b>0.33</b>	—	-0.01	-0.03	0.06
Doñana	<b>0.34</b>	<b>0.26</b>	<b>0.32</b>	0	—	-0.01	0.04
Tuzla	<b>0.36</b>	<b>0.28</b>	<b>0.36</b>	0.01	-0.01	—	-0.03
Kujalnik	<b>0.38</b>	<b>0.28</b>	<b>0.35</b>	0	0	0	—

Snowy and White-fronted plovers (6.5%). Interpopulation comparisons within *C. a. alexandrinus* or *C. a. nivosus* did not reveal any significant differences between any pairs of populations (all average net sequence differences  $< 0.1\%$ ).

The  $\Phi_{st}$  values among the three groups were highly pronounced. The results were consistent with highly significant pairwise  $\Phi_{st}$  values for comparisons between single populations of the three groups (Table 2; range: 0.93–1,  $P < 0.001$ ). Within groups,  $\Phi_{st}$  values were low, ranging from -0.03 (Al Wathba vs. Tuzla) to 0.06 (Al Wathba vs. Kujalnik), and none of the pairwise interpopulation comparisons was significant (all comparisons,  $P > 0.05$ ). The AMOVA revealed that most of the mtDNA variation was attributable to the differences among the three groups (explained variation = 97.8%,  $df = 2$ ,  $P < 0.001$ ). Very little variation was explained by population (explained variation = 0.02%,  $df = 4$ ,  $P = 0.39$ ), and little variation was harbored within populations (explained variation = 2.2%,  $df = 46$ ,  $P = 0.01$ ).

**Nuclear markers.**—The size of CHD-W fragments among all female plovers was 381 bp ( $n = 91$ ). However, the sizes of CHD-Z fragments differed. The typical size for the amplified CHD-Z fragment was 373 bp in Kentish Plovers ( $n = 112$  individuals) and White-fronted Plovers ( $n = 19$  individuals). Two male Kentish Plovers, one from Tuzla and one from Al Wathba, were heterozygous, with an additional Z allele of estimated size 371 bp in addition to their 373-bp allele. The CHD-Z fragment in Snowy Plovers was consistently shorter, with a length of 365 bp ( $n = 35$  individuals), and all males were homozygous.

The microsatellite allele size ranges differed between populations at three loci (Table 3). One marker, Calex-28, did not amplify in Snowy Plovers, although it amplified in 110 of 112 Kentish Plovers and 15 of 19 White-fronted Plovers. Allele sizes did not overlap between Snowy Plover and Kentish–White-fronted Plover at loci Calex-10 and Calex-39. One marker (Calex-10) had significant homozygote excess in Kentish Plovers breeding in Tuzla. Significant linkage disequilibria were detected among three pairs of microsatellite loci: Calex-02 and C201, Calex-23 and C203, and C204 and C205. Therefore, we excluded Calex-10, Calex-28, C201, C203, and C205 and used only 21 unlinked markers that were amplified across all individuals for the Bayesian analysis and  $F_{st}$  value calculations.

**Genetic diversity estimated from microsatellites.**—Genetic variation (microsatellite heterozygosity corrected for sample size according to Nei 1978) was different across plover populations (Table 3; Kruskal-Wallis test:  $\chi^2 = 103.80$ ,  $df = 6$ ,  $P < 0.001$ ).

Heterozygosities corrected for sample sizes did not differ between populations of Snowy and White-fronted plovers (Wilcoxon rank-sum tests: in all possible comparisons,  $P > 0.46$ ). However, the four Kentish Plover populations harbored substantially more genetic variation than the two Snowy Plover populations (Wilcoxon rank-sum tests: in all pairwise comparisons,  $P < 0.001$ ). All loci were polymorphic in Kentish Plover populations, but not in White-fronted and Snowy plover populations.

**Genetic differentiation estimated from microsatellites.**— $F_{st}$  values for 21 microsatellites revealed strong differentiation among Kentish, Snowy, and White-fronted plovers (range: 0.27–0.62; Table 2). Consistent with the mitochondrial results, within groups the pairwise  $F_{st}$  values were not significantly different from zero (range: 0–0.01).

The AMOVA showed that a large proportion of the variation in allele frequencies was explained by the three putative main groups (explained variation = 33.8%,  $df = 2$ ,  $P < 0.001$ ). As with mitochondrial DNA (mtDNA), little variation was explained by the actual population membership (explained variation = 0.4%,  $df = 4$ ,  $P = 0.01$ ). However, in contrast to the mtDNA, the largest part of the variation was harbored within populations (explained variation = 65.8%,  $df = 325$ ,  $P = 0.01$ ).

Despite the long burn-in and run-time (1,000,000 generations each), the Bayesian analyses using STRUCTURE produced inconsistent results regarding the number of clusters. Log likelihood values (average: -10,880) were maximal for the majority of iterations (6 of 10) when  $K$  was set to three populations. In these runs, major groups Snowy Plover, White-fronted Plover, and Kentish Plover were clustered separately with assignment probabilities  $> 0.98$  for each individual. In the four remaining runs for  $K = 3$ , log likelihood values were substantially lower (average: -12,302). In these runs, White-fronted Plover and Snowy Plover were always clustered together, whereas the genotypes of Kentish Plovers were partly assigned into two clusters with average assignment probabilities  $< 0.65$ .  $\Delta K$  values peaked for  $K = 2$ , which suggests two clusters. However, similar inconsistencies as for  $K = 3$  were found: in 6 of 10 runs, White-fronted Plovers were grouped with Kentish Plovers, whereas in the remaining four runs White-fronted Plovers were grouped together with Snowy Plovers. Importantly, in not a single simulation for  $K > 1$  ( $n = 60$ ) were Snowy Plover and Kentish Plover clustered together.

Using BAPS, we identified three clusters among the sampled plovers with a probability of 0.98. The assignment probability for

TABLE 3. Allele sizes and genetic variation in two Snowy Plover, one White-fronted Plover, and four Kentish Plover populations, measured by 26 autosomal microsatellite loci ( $n$  = number of individuals genotyped,  $A$  = number of alleles found in population sample, and  $H_e$  = heterozygosity corrected for sample size according to Nei [1978]).

Locus <sup>a</sup>	Snowy Plover						White-fronted Plover						Kentish Plover											
	Ceuta		Salt Lake		Madagascar		Al Wathba		Doñana		Tuzla		Kujalnik											
	$n$	$A$	$n$	$A$	$n$	$A$	$n$	$A$	$n$	$A$	$n$	$A$	$n$	$A$	$n$	$A$	$n$	$A$	$H_e$	Allele range				
FAMC201 <sup>b</sup>	30	2	0.38	127–131	19	3	0.28	133–139	30	11	0.90	127–149	30	12	0.87	129–157	30	15	0.90	125–163	22	11	0.86	129–157
NEDC203 <sup>b</sup>	30	6	0.57	175–191	19	1	0	179	30	14	0.82	179–204	30	10	0.85	179–199	30	12	0.82	179–208	21	10	0.81	178–201
FAMC204 <sup>b</sup>	30	7	0.73	199–213	4	4	0.75	199–207	19	8	0.81	195–211	29	16	0.91	187–229	30	18	0.89	187–239	22	12	0.89	195–231
HEXC205 <sup>b</sup>	30	2	0.36	179–181	4	2	0.43	179–181	19	4	0.29	177–193	29	8	0.86	177–195	29	10	0.87	167–195	22	8	0.84	177–195
FAMCalex-01 <sup>c</sup>	30	1	0	239	5	1	0	239	19	1	0	239	29	9	0.74	241–257	30	10	0.80	239–259	22	11	0.85	239–259
PEXCalex-02 <sup>c</sup>	30	2	0.35	146–150	5	2	0.53	146–150	18	3	0.30	152–158	30	11	0.89	146–168	30	11	0.86	152–174	30	15	0.90	144–182
NEDCalex-04 <sup>c</sup>	30	2	0.36	213–215	19	4	0.29	211–227	30	8	0.85	211–229	29	9	0.86	211–229	30	10	0.87	201–229	22	8	0.84	211–229
FAMCalex-05 <sup>c</sup>	30	3	0.37	185–187	5	4	0.53	185–188	19	1	0	189	30	7	0.73	187–193	30	6	0.62	187–192	22	6	0.61	187–192
HEXCalex-08 <sup>c</sup>	30	2	0.03	226–228	5	1	0	228	19	1	0	224	30	5	0.70	222–230	30	5	0.65	223–230	22	4	0.72	224–230
HEXCalex-10 <sup>c,d</sup>	30	3	0.42	214–220	5	2	0.53	214–216	19	2	0.27	203–205	25	3	0.57	201–205	25	3	0.60	201–205	19	2	0.42	203–205
NEDCalex-11 <sup>c</sup>	30	1	0	155	5	1	0	155	19	2	0.50	154–155	26	9	0.84	154–163	26	9	0.85	151–162	20	9	0.86	154–163
FAMCalex-12 <sup>c</sup>	30	4	0.65	390–396	5	2	0.47	390–392	19	2	0.05	373–375	29	8	0.79	382–396	30	8	0.85	373–396	21	6	0.81	386–396
HEXCalex-14 <sup>c</sup>	30	7	0.74	200–214	5	4	0.82	200–208	19	8	0.81	196–212	29	14	0.88	188–220	30	17	0.91	188–230	22	12	0.89	196–231
HEXCalex-18 <sup>c</sup>	30	2	0.07	159–161	5	1	0	159	19	4	0.63	161–169	30	10	0.86	149–171	30	8	0.85	155–171	22	9	0.83	153–171
HEXCalex-19 <sup>c</sup>	30	2	0.44	295–303	5	2	0.53	295–303	19	3	0.53	303–305	30	11	0.86	296–311	30	10	0.87	296–310	22	10	0.85	301–314
HEXCalex-22 <sup>c</sup>	30	1	0	314	5	1	0	314	18	4	0.70	316–322	29	6	0.63	312–324	30	4	0.51	316–324	21	4	0.63	316–324
PEXCalex-23 <sup>c</sup>	30	5	0.55	232–246	5	3	0.64	236–246	19	1	0	234	30	15	0.84	234–259	30	11	0.85	234–254	22	10	0.80	229–256
FAMCalex-24 <sup>c</sup>	30	1	0	112	5	1	0	112	19	1	0	86	30	7	0.62	86–114	30	5	0.59	86–114	22	4	0.64	86–112
NEDCalex-28 <sup>c</sup>	NA	NA	NA	NA	15	3	0.48	218–222	29	7	0.82	208–224	30	8	0.78	208–226	29	7	0.76	208–224	22	6	0.69	208–220
FAMCalex-32 <sup>c</sup>	30	4	0.67	182–196	4	3	0.61	188–196	19	3	0.53	184–196	30	7	0.64	178–192	30	4	0.61	178–192	21	6	0.74	178–194
HEXCalex-35 <sup>c</sup>	30	4	0.58	147–153	4	2	0.54	151–153	19	4	0.43	127–155	30	11	0.81	127–165	30	13	0.77	127–159	22	8	0.76	127–186
PEXCalex-37 <sup>c</sup>	30	1	0	178	5	1	0	178	19	2	0.19	174–178	29	9	0.81	166–198	29	10	0.84	166–196	21	11	0.88	166–204
HEXCalex-39 <sup>c</sup>	30	4	0.33	106–112	5	1	0	110	19	4	0.15	135–145	30	19	0.94	114–169	30	11	0.86	124–145	22	16	0.88	124–155
FAMCalex-43 <sup>c</sup>	30	5	0.56	389–395	5	3	0.51	389–393	19	7	0.79	388–404	30	21	0.94	374–434	29	19	0.94	373–423	22	17	0.95	374–404
FAMCalex-45 <sup>c</sup>	30	2	0.07	254–256	5	1	0	256	19	2	0.05	258–262	30	11	0.82	253–292	30	10	0.82	256–284	22	12	0.87	253–284
NEDHru2 <sup>e</sup>	30	3	0.52	148–152	3	3	0.73	148–154	19	1	0	146	29	6	0.69	138–148	29	6	0.72	138–148	22	6	0.65	138–148
All loci	3.0	0.35			2.1	0.36			3.0	0.31			10.1	0.79			9.5	0.79		10.6	0.81		8.7	0.78

<sup>a</sup>FAM, HEX, NED, and PET are fluorescent labels of the forward primers.  
<sup>b</sup>Primers for this locus were originally developed for American Snowy Plovers (Funk et al. 2007).  
<sup>c</sup>Primers for this locus were originally developed for Eurasian Kentish Plovers (Küpper et al. 2007).  
<sup>d</sup>Locus not in Hardy-Weinberg equilibrium, but with homozygote excess when tested in 30 Kentish Plovers breeding in Tuzla.  
<sup>e</sup>Primers for this locus were originally developed for Barn Swallow (Primmer et al. 1995).

each individual genome in the mixture analysis was 1.00, based on 50 simulations from posterior allele frequencies.

*Biometry of adults and chicks.*—The morphometric body characteristics of adult plovers differed between populations after controlling for sex (Table 4). The contrast analysis revealed that these differences existed largely because Snowy Plovers were smaller than Kentish Plovers (Table 4; contrast analysis: tarsus length:  $t = 26.68$ ,  $df = 4$  and  $395$ ,  $P < 0.001$ ; wing length:  $t = 7.68$ ,  $df = 4$  and  $395$ ,  $P < 0.001$ ; body mass:  $t = 9.18$ ,  $df = 4$  and  $395$ ,  $P < 0.001$ ). There was no significant difference in tarsus length between Kentish Plover populations (in all tests  $P > 0.25$ ). Wing length differed between Kentish Plover populations, with individuals from either Tuzla or Al Wathba having significantly shorter wings than individuals from either Doñana or Miklapuszta (*post-hoc* Tukey test: for each comparison,  $P < 0.01$ ). However, Kentish Plovers from three of the four sampled populations (Al Wathba, Doñana, and Miklapuszta) had significantly longer wings than Snowy Plovers from Ceuta (Table 4; *post-hoc* Tukey tests: in all tests,  $P < 0.001$ ), and there was a strong trend for Kentish Plovers from the fourth population (Tuzla) to have longer wings than Snowy Plovers from Ceuta (Table 4; *post-hoc* Tukey test:  $P = 0.06$ ).

Snowy Plover chicks had shorter tarsi than Kentish Plover chicks; however, there was no difference in their body mass (Table 4; contrast analysis: tarsus:  $t = 6.94$ ,  $df = 40$ ,  $P < 0.001$ ; body mass:  $t = 1.50$ ,  $df = 40$ ,  $P = 0.14$ ). The results of *post-hoc* Tukey tests showed no significant differences in body mass between Kentish Plover hatchlings (in all tests  $P > 0.43$ ) but revealed further significant differences in hatchling tarsus length between Kentish Plover populations. Chicks from Miklapuszta had longer tarsi than chicks from Al Wathba ( $\Delta$  mean = 1.54 mm,  $P < 0.001$ ) and chicks from Doñana ( $\Delta$  mean = 1.19 mm,  $P < 0.01$ ). However, even the smallest Kentish Plover chicks that originated from the Al Wathba population had longer tarsi than the Snowy Plover chicks from Ceuta (*post-hoc* Tukey test:  $\Delta$  mean = 1.13 mm,  $P = 0.01$ ).

DISCUSSION

Our study produced four major results regarding the taxonomy and phylogeography of Kentish, Snowy, and White-fronted plovers. First, we found profound genetic differences between Snowy and Kentish plovers. The magnitude of genetic differences among Kentish, Snowy, and White-fronted plovers, measured by both mitochondrial and nuclear markers, suggests that the split between Kentish and Snowy plovers occurred earlier than the split between Kentish and White-fronted plovers. Second, Kentish Plovers showed higher genetic diversity in mitochondrial haplotypes and microsatellite markers than Snowy Plovers. Third, we detected no population differentiation within each subspecies, despite large distances between sample locations, up to several thousand kilometers, in both Snowy and Kentish plovers. Fourth, the genetic differences between Kentish and Snowy plovers also reflect phenotypic differences between both groups.

*Genetic differences among Kentish, Snowy, and White-fronted plovers.*—Examination of mitochondrial and nuclear markers (CHD and microsatellite loci) showed that Kentish and Snowy plovers have consistent genetic differences. This indicates that the current oceanic barriers prevent detectable gene flow between the Eurasian and American populations. The magnitude of the genetic

TABLE 4. Biometrics of Snowy and Kentish plovers (means  $\pm$  SD). Forty males, 40 females, and 9 chicks during the first 24 h after hatching were measured from each breeding populations. Summary statistics of two-way ANOVAs for adults and one-way ANOVAs for chicks from minimum adequate models are presented on the right.

	Snowy Plover			Kentish Plover			Sex		Population			Sex* population			Residual	
	Ceuta	Al Wathba	Doñana	Tuzla	Miklapuszta	df	F	P	df	F	P	df	F	P	df	df
Adult males																
Tarsus length (mm)	25.56 $\pm$ 0.67	29.15 $\pm$ 1.36	29.44 $\pm$ 0.94	29.22 $\pm$ 0.96	29.39 $\pm$ 1.32	1	43.5	<0.001	4	198.2	<0.001	—	—	—	—	394
Wing length (mm)	108.59 $\pm$ 2.57	110.33 $\pm$ 3.83	112.31 $\pm$ 2.44	108.90 $\pm$ 3.54	111.45 $\pm$ 3.36	1	4.2	0.04	4	28.6	<0.001	—	—	—	—	394
Body mass (g)	38.48 $\pm$ 2.72	36.95 $\pm$ 2.86	40.66 $\pm$ 2.43	40.76 $\pm$ 2.09	44.75 $\pm$ 3.00	1	1.8	0.19	4	108.5	<0.001	4	2.55	0.04	—	390
Adult females																
Tarsus length (mm)	24.78 $\pm$ 0.89	28.39 $\pm$ 1.15	28.56 $\pm$ 0.97	28.61 $\pm$ 1.07	28.85 $\pm$ 1.29											
Wing length (mm)	106.55 $\pm$ 3.47	109.25 $\pm$ 2.79	111.79 $\pm$ 3.18	108.89 $\pm$ 2.91	111.88 $\pm$ 2.91											
Body mass (g)	37.76 $\pm$ 2.48	37.17 $\pm$ 2.90	41.74 $\pm$ 2.07	42.22 $\pm$ 2.20	44.43 $\pm$ 2.70											
Chicks																
Tarsus length (mm)	17.44 $\pm$ 0.54	18.57 $\pm$ 0.94	18.92 $\pm$ 0.36	19.35 $\pm$ 0.69	20.11 $\pm$ 0.79	—	—	—	4	18.2	<0.001	—	—	—	—	40
Body mass (g)	5.99 $\pm$ 0.41	6.39 $\pm$ 0.56	6.28 $\pm$ 0.63	6.31 $\pm$ 0.44	6.01 $\pm$ 0.36	—	—	—	4	1.1	0.38	—	—	—	—	40

differences suggests that gene flow has been absent for a considerable time (Price 2007).

We found good support from all genetic markers for the hypothesis that Snowy Plovers diverged from Kentish Plovers before the divergence of Kentish and White-fronted plovers. Differences between mtDNA sequences and CHD-Z genotypes were larger between Kentish and Snowy plovers (6%) than between Kentish and White-fronted plovers (2%). In trees obtained from mitochondrial phylogenetic analyses by parsimony, Bayesian inference, or distance methods (neighbor-joining tree; data not shown), Snowy Plovers diverged first from the Kentish–White-fronted plover lineage. A preceding split of Snowy Plover from Kentish Plover was also supported by the microsatellite analysis, because microsatellite allele ranges completely overlapped between White-fronted and Kentish plovers but were distinct between Snowy and Kentish plovers at two loci. One other marker, Calx-28, consistently failed to amplify in Snowy Plovers, although it amplified in Kentish and White-fronted plovers. Both  $F_{st}$  and  $\Phi_{st}$  values were larger between Snowy and either White-fronted or Kentish plover populations than between Kentish and White-fronted plover populations, although the differences were small.

Population assignment using Bayesian inference produced consistent results with the other population genetic analyses when BAPS was employed, but the results were more complex when STRUCTURE was employed: a *post-hoc* analysis using the method described by Evanno et al. (2005) suggested two clusters, although White-fronted Plovers were clustered with Kentish Plovers in 60% of these runs, whereas they were clustered in the remaining runs with Snowy Plovers. When we used a combination of parameters (highest assignment probability, maximal log likelihood), we received best support ( $K = 3$ ), in line with the results of BAPS. Disagreement in determining the number of clusters between STRUCTURE and BAPS has been reported before (e.g., Corander and Marttinen 2006, Schug et al. 2007). Corander and Marttinen (2006) discussed the difficulties involved in the simultaneous estimation of clusters and the advantages of performing individual analyses prior to the admixture analysis performed in BAPS.

*Genetic diversity.*—Populations showed consistent differences in genetic diversity according to their origin. All four Kentish Plover populations harbored high genetic diversity as measured by microsatellite and mtDNA markers, whereas the diversity was lower in Snowy and White-fronted plovers. The differences in diversity could be biased by the markers chosen, because 21 of the 26 microsatellite markers were developed in Kentish Plovers, and the variability of microsatellite markers usually drops with evolutionary distance from their source species (Dawson et al. 2005, Primmer et al. 2005). However, heterozygosities of the four markers that were specifically developed for the Snowy Plover (Funk et al. 2007) or for the Barn Swallow (Primmer et al. 1995) also were higher in Kentish Plovers than in Snowy and White-fronted plovers. Furthermore, mitochondrial sequences in Kentish Plovers were more diverse than those in Snowy Plovers, and this difference cannot be explained by any ascertainment bias of microsatellite markers.

*Large panmictic populations.*—The breeding populations of both Snowy and Kentish plovers have become increasingly fragmented, probably as a result of human alterations of their habitat.

However,  $F_{st}$  and  $\Phi_{st}$  analyses did not indicate genetic structuring. This result suggests that there are no barriers to gene flow over large distances within the analyzed subspecies. Mitochondrial haplotypes were not associated with geography in both *C. a. nivosus* and *C. a. alexandrinus*. Several Kentish Plovers from Spain and UAE shared the same haplotype, although these locations are separated by ~6,000 km. The Bayesian analyses did not find differences between microsatellite profiles of plovers within Eurasia or within America and assigned all individuals from each subspecies into the same cluster. A lack of population structure also has been found in some other shorebird species (Ottvall et al. 2005, Oyler-McCance et al. 2005, Marthinsen et al. 2007). Funk et al. (2007) evaluated population and subspecies differentiation in American Snowy Plovers. Genetic data supported subspecies differentiation, but remote populations within the best-analyzed subspecies, *C. a. nivosus*, were not genetically differentiated. The *C. a. nivosus* sampling of Funk et al. (2007) was restricted to sites in the United States, and our results indicate that Pacific Snowy Plovers that breed >1,000 km farther south in Mexico belong to this subspecies and that gene exchange with the northern populations is not restricted. This is important for conservation management of Snowy Plover. Note that the differences between the American Snowy Plover subspecies in Funk et al. (2007) were much smaller than the differences between the intercontinental groups that we have presented here.

The panmixia stands in contrast to the morphological differences observed in different populations, which suggest local adaptation or gene\*environment interactions. A lack of genetic structure despite phenotypic variation also was observed in another shorebird, the Dunlin (*Calidris alpina*). Marthinsen et al. (2007) examined the genetic differentiation of Dunlin subspecies that belonged to two separate mitochondrial lineages using amplified fragment length polymorphism (AFLP) and microsatellite markers. Subspecies that were initially defined according to plumage, morphometrics, and behavior could not be distinguished according to AFLP or microsatellite allele patterns, although microsatellites (but not AFLP markers) showed a clinal change in allele frequencies.

*Phenotypic differences between Kentish and Snowy plovers.*—

The biometric measurements of tarsus and wing length showed that Kentish Plovers are consistently larger than Snowy Plovers and, on average, Kentish Plovers also were significantly heavier than Snowy Plovers. However, male and female Kentish Plovers breeding in Al Wathba were lighter than Snowy Plovers from Ceuta breeding at similar latitudes. Ecological constraints such as the increase of body mass over surface ratio with latitude (Bergmann 1847, Rensch 1938, James 1970, Blackburn et al. 1999) could be responsible for the observed differences. Additional populations, particularly of Snowy Plovers breeding at higher latitudes, need to be sampled to examine the influence of latitude on body mass.

Male advertising calls and chick plumage appear to provide further diagnostic characters to discriminate between Kentish and Snowy plovers (see Appendix). Given that patterns of downy plumage show consistent differences between shorebird species and have been used to construct a shorebird phylogeny (Jehl 1968), they may serve as a suitable character to separate Snowy and Kentish plovers. This is somewhat surprising, because downy

plumage has an essential role in camouflaging the chicks and is expected to be driven by local ecology (e.g., soil and substrate patterns). Adult plumage in Snowy and Kentish plovers shows more variation within and across subspecies, which was the main reason why both groups were merged into a single species (Oberholser 1922). We noticed during our field studies in Mexico and Eurasia that adult sexual dimorphism is reduced in Snowy Plovers. In the beginning of the breeding season, female Snowy Plovers exhibit black head- and breast-badges that make them almost indistinguishable from males, whereas most male Kentish Plovers are brightly colored and, thus, easily distinguished from females in the beginning of the breeding season.

Our suggested phylogenetic relationships among Snowy, Kentish, and White-fronted Plovers are consistent with the hypothesis that transitions between different breeding systems have frequently occurred in the phylogenetic history of shorebirds (Székely and Reynolds 1995). In shorebirds, biparental care is considered the ancestral state, and uniparental male care is rare in Charadrii (Székely and Reynolds 1995). The genetic results presented here suggest that Snowy Plover diverged from the common ancestor of Kentish and White-fronted plovers. However, Snowy and Kentish plovers both have high levels of uniparental male care and polyandry, with 27–37% of the deserting females re-mating (Warriner et al. 1986, Székely and Williams 1995, Amat et al. 1999). By contrast, the White-fronted Plover is considered monogamous with biparental care, and brood desertion by either sex has not been reported (Lloyd 2008). Hence, the most parsimonious explanation for the current breeding system in White-fronted Plover is that biparental care has evolved from an ancestral state of uniparental care.

Our main aim was to investigate the divergence between Eurasian and American populations, and we discovered strong differentiation. A limitation of our study, however, is that we did not include all six subspecies of *C. alexandrinus*. For a comprehensive phylogeographic analysis and a robust phylogeny of the entire superspecies, more sampling will be necessary. However, the populations sampled in Eurasia all belong to the subspecies *C. a. alexandrinus*, which has the largest distribution range of all the subspecies of *C. alexandrinus*, and the comparison of these populations with the most widely distributed subspecies in America, *C. a. nivosus*, showed strongly pronounced differences that warrant a reconsideration of the current classification of the Kentish–Snowy Plover as a cosmopolitan species. As mentioned above, an investigation of subspecies differentiation in Snowy Plovers has been conducted previously (Funk et al. 2007). A further fine-scale phylogenetic analysis, including populations of Red-capped Plovers, Javan Plovers, and samples from the subspecies *C. a. seebohmi* and *C. a. dealbatus*, combined with a more distantly related outgroup, may reveal further cryptic species and will help us to gain better understanding of the phylogenetic history of this species complex.

We have shown that Kentish and Snowy plovers should no longer be considered to constitute a single cosmopolitan species. We recommend that the systematic status and nomenclature of *C. alexandrinus* should be changed to recognize the Snowy Plover as a distinct species. We propose to reinstate *C. nivosus* as the name for the three American subspecies and to confine *C. alexandrinus* to the three Eurasian subspecies according to the original classification made by Cassin in 1858. The “cosmopolitan” label often depends on

conservative taxonomy that often does not hold when the phylogeography is investigated thoroughly (e.g., Klautau et al. 1999, Bleidorn et al. 2006). Since molecular techniques became available, many species that were classified based on morphological characters alone have been found to consist of multiple cryptic species (reviewed by Bickford et al. 2007). Among shorebirds, the other currently considered cosmopolitan species, the Black-winged Stilt (Hayman et al. 1986, del Hoyo et al. 1996), shows several different geographic morphotypes and could potentially harbor several cryptic species.

#### ACKNOWLEDGMENTS

S. Haig, J. St Clair, and S. Zefania kindly provided blood or DNA samples of populations. M. Bucio Pacheco, J. Chernichko, O. Formanyuk, S. Javed, P. Panchenko, and T. Yilmaz helped with the logistics of field work during sampling. We are grateful to G. Horsburgh for advice on the manual sequence editing using CODON-CODE ALIGNER. M. Wills advised on the phylogenetic analysis. P. Long helped prepare the population map. L. Elliot, J. Roché, and the British Library Sound Archive provided records of high-quality plover calls. H. Hipperson, K. Scribner, J. St Clair, M. Wills, and three anonymous reviewers provided valuable comments on the manuscript. Funding was provided by the Natural Environmental Research Council (NE/C004167/1 and MGF184), Biotechnology and Biological Sciences Research Council (BBS/B/05788), Leverhulme Trust (RF/2/RFG/2005/0279), National Geographic Society (8403-08), and European Community (FP6 GEBACO 28696, FP6 INCORE 043318, and access to research infrastructure action of the Improving Human Potential Programme at the Doñana Biological Station). C.K. was funded by a University of Bath studentship, and A.K. was supported by a Magyary Postdoctoral Fellowship. D. A. Dawson's bird sex-marker web page is at [www.shef.ac.uk/misc/groups/molecol/BirdsexingSMGF.xls](http://www.shef.ac.uk/misc/groups/molecol/BirdsexingSMGF.xls). The EBI–Transeq tool is available at [www.ebi.ac.uk/emboss/transeq/](http://www.ebi.ac.uk/emboss/transeq/).

#### LITERATURE CITED

- AKAIKE, H. 1974. A new look at the statistical model identification. *IEEE Transactions on Automatic Control*, AC-19:716–723.
- AMAT, J. A., R. M. FRAGA, AND G. M. ARROYO. 1999. Brood desertion and polygamous breeding in the Kentish Plover *Charadrius alexandrinus*. *Ibis* 141:596–607.
- BAKER, A. J., S. L. PEREIRA, AND T. A. PATON. 2007. Phylogenetic relationships and divergence times of Charadriiformes genera: Multigene evidence for the Cretaceous origin of at least 14 clades of shorebirds. *Biology Letters* 3:205–209.
- BERGMANN, C. 1847. Über die Verhältnisse der Wärmeökonomie der Thiere zu ihrer Grösse. *Göttinger Studien* 3:595–708.
- BICKFORD, D., D. J. LOHMAN, N. S. SODHI, P. K. L. NG, R. MEIER, K. WINKER, K. K. INGRAM, AND I. DAS. 2007. Cryptic species as a window on diversity and conservation. *Trends in Ecology and Evolution* 22:148–155.
- BIRDLIFE INTERNATIONAL. 2007. Species factsheet: *Charadrius alexandrinus*. [Online.] Available at [www.birdlife.org/datazone/species/index.html](http://www.birdlife.org/datazone/species/index.html).
- BLACKBURN, T. M., K. J. GASTON, AND N. LODER. 1999. Geographic gradients in body size: A clarification of Bergmann's rule. *Diversity and Distributions* 5:165–174.

- BLEIDORN, C., I. KRUSE, S. ALBRECHT, AND T. BARTOLOMAEUS. 2006. Mitochondrial sequence data expose the putative cosmopolitan polychaete *Scoloplos armiger* (Annelida, Orbiniidae) as a species complex. *BMC Evolutionary Biology* 6:47.
- BLOMQUIST, D., M. ANDERSSON, C. KÜPPER, I. C. CUTHILL, J. KIS, R. B. LANCTOT, B. K. SANDERCOCK, T. SZÉKELY, J. WALLANDER, AND B. KEMPENAERS. 2002. Genetic similarity between mates and extra-pair parentage in three species of shorebirds. *Nature* 419:613–615.
- BRUFORD, M. W., O. HANOTTE, J. F. Y. BROOKFIELD, AND T. BURKE. 1998. Multilocus and single-locus DNA fingerprinting. Pages 287–336 in *Molecular Genetic Analysis of Populations: A Practical Approach* (A. R. Hoelzel, Ed.). IRL Press, Oxford.
- CHESSER, R. T. 1999. Molecular systematics of the rhinocryptid genus *Pteroptochos*. *Condor* 101:439–446.
- CORANDER, J., AND P. MARTTINEN. 2006. Bayesian identification of admixture events using multilocus molecular markers. *Molecular Ecology* 15:2833–2843.
- CORANDER, J., P. WALDMANN, AND M. J. SILLANPÄÄ. 2003. Bayesian analysis of genetic differentiation between populations. *Genetics* 163:367–374.
- CRAMP, S., ED. 1983. *Handbook of the Birds of Europe, the Middle East and North Africa: The Birds of the Western Palearctic, vol. 3: Waders to Gulls*. Oxford University Press, New York.
- DAWSON, D. A., J. CHITTOCK, R. JEHL, A. WHITLOCK, D. NOGUEIRA, J. PELLATT, T. BIRKHEAD, AND T. BURKE. 2005. Identification of 13 polymorphic microsatellite loci in the Zebra Finch, *Taeniopygia guttata* (Passeridae, Aves). *Molecular Ecology Notes* 5:298–301.
- DEL HOYO, J., A. ELLIOTT, AND J. SARGATAL, Eds. 1996. *Handbook of the Birds of the World, vol. 3: Hoatzin to Auks*. Lynx Edicions, Barcelona, Spain.
- EBERHARD, J. R., AND E. BERMINGHAM. 2004. Phylogeny and biogeography of the *Amazona ochrocephala* (Aves: Psittacidae) complex. *Auk* 121:318–332.
- ERICSON, P. G. P., I. ENVALL, M. IRESTEDT, AND J. A. NORMAN. 2003. Inter-familial relationships of the shorebirds (Aves: Charadriiformes) based on nuclear DNA sequence data. *BMC Evolutionary Biology* 3:16.
- EVANNO, G., C. REGNAUT, AND J. GOUDET. 2005. Detecting the number of clusters of individuals using the software STRUCTURE: A simulation study. *Molecular Ecology* 14:2611–2620.
- EXCOFFIER, L., G. LAVAL, AND S. SCHNEIDER. 2005. Arlequin (version 3.0): An integrated software package for population genetics data analysis. *Evolutionary Bioinformatics Online* 1:47–50.
- EXCOFFIER, L., P. E. SMOUSE, AND J. M. QUATTRO. 1992. Analysis of molecular variance inferred from metric distances among DNA haplotypes: Application to human mitochondrial DNA restriction data. *Genetics* 131:479–491.
- FENCHEL, T., AND B. J. FINLAY. 2004. The ubiquity of small species: Patterns of local and global diversity. *BioScience* 54:777–784.
- FUNK, W. C., T. D. MULLINS, AND S. M. HAIG. 2007. Conservation genetics of Snowy Plovers (*Charadrius alexandrinus*) in the Western Hemisphere: Population genetic structure and delineation of subspecies. *Conservation Genetics* 8:1287–1309.
- GASTON, K. J. 2003. *The Structure and Dynamics of Geographic Ranges*. Oxford University Press, Oxford, United Kingdom.
- GRIFFITHS, R., M. C. DOUBLE, K. ORR, AND R. J. G. DAWSON. 1998. A DNA test to sex most birds. *Molecular Ecology* 7:1071–1075.
- HARDY, O. J., AND X. VEKEMANS. 2002. SPAGeDi: A versatile computer program to analyse spatial genetic structure at the individual or population levels. *Molecular Ecology Notes* 2:618–620.
- HASEGAWA, M., H. KISHINO, AND T. YANO. 1985. Dating of the human–ape splitting by a molecular clock of mitochondrial DNA. *Journal of Molecular Evolution* 22:160–174.
- HAYMAN, P., J. MARCHANT, AND T. PRATER. 1986. *Shorebirds: An Identification Guide to the Waders of the World*. Houghton Mifflin, Boston.
- HUELSENBECK, J. P., AND F. RONQUIST. 2001. MRBAYES: Bayesian inference of phylogenetic trees. *Bioinformatics* 17:754–755.
- JAMES, F. C. 1970. Geographic size variation in birds and its relationship to climate. *Ecology* 51:365–390.
- JEHL, J. R., JR. 1968. Relationships in the Charadrii (shorebirds): A taxonomic study based on color patterns of the downy young. *San Diego Society of Natural History Memoirs*, no. 3.
- KLAUTAU, M., C. A. M. RUSSO, C. LAZOSKI, N. BOURY-ESNAULT, J. P. THORPE, AND A. M. SOLÉ-CAVA. 1999. Does cosmopolitanism result from overconservative systematics? A case study using the marine sponge *Chondrilla nucula*. *Evolution* 53:1414–1422.
- KOSZTOLÁNYI, A., T. SZÉKELY, I. C. CUTHILL, K. T. YILMAZ, AND S. BERBEROĞLU. 2006. Ecological constraints on breeding system evolution: The influence of habitat on brood desertion in Kentish Plover. *Journal of Animal Ecology* 75:257–265.
- KROKENE, C., K. ANTHONISEN, J. T. LIFJELD, AND T. AMUNDSEN. 1996. Paternity and paternity assurance behaviour in the Bluethroat, *Luscinia s. svecica*. *Animal Behaviour* 52:405–417.
- KÜPPER, C., G. J. HORSBURGH, D. A. DAWSON, R. FRENCH-CONSTANT, T. SZÉKELY, AND T. BURKE. 2007. Characterization of 36 polymorphic microsatellite loci in the Kentish Plover (*Charadrius alexandrinus*) including two sex-linked loci and their amplification in four other *Charadrius* species. *Molecular Ecology Notes* 7:35–39.
- KÜPPER, C., J. KIS, A. KOSZTOLÁNYI, T. SZÉKELY, I. C. CUTHILL, AND D. BLOMQUIST. 2004. Genetic mating system and timing of extra-pair fertilizations in the Kentish Plover. *Behavioral Ecology and Sociobiology* 57:32–39.
- LESSELLS, C. M. 1984. The mating system of Kentish Plovers *Charadrius alexandrinus*. *Ibis* 126:474–483.
- LLOYD, P. 2008. Adult survival, dispersal and mate fidelity in the White-fronted Plover *Charadrius marginatus*. *Ibis* 150:182–187.
- MARTHINSEN, G., L. WENNERBERG, AND J. T. LIFJELD. 2007. Phylogeography and subspecies taxonomy of Dunlins (*Calidris alpina*) in western Palearctic analysed by DNA microsatellites and amplified fragment length polymorphism markers. *Biological Journal of the Linnean Society* 92:713–726.
- MONROE, B. L., JR., AND C. G. SIBLEY. 1993. *A World Checklist of Birds*. Yale University Press, New Haven, Connecticut.
- NEI, M. 1978. Estimation of average heterozygosity and genetic distance from a small number of individuals. *Genetics* 89:583–590.
- NICHOLLS, J. A., M. C. DOUBLE, D. M. ROWELL, AND R. D. MAGRATH. 2000. The evolution of cooperative and pair breeding in thornbills *Acanthiza* (Pardalotidae). *Journal of Avian Biology* 31:165–176.
- NYLANDER, J. A. A. 2004. MrModeltest, version 2. Software distributed by the author. [Online.] Available at [www.abc.se/~nylander/](http://www.abc.se/~nylander/).

- OBERHOLSER, H. C. 1922. Notes on North American birds. XI. *Auk* 39:72–78.
- OTTVALL, R., J. HÖGLUND, S. BENSCH, AND K. LARSSON. 2005. Population differentiation in the Redshank (*Tringa totanus*) as revealed by mitochondrial DNA and amplified fragment length polymorphism markers. *Conservation Genetics* 6:321–331.
- OYLER-McCANCE, S. J., J. ST. JOHN, F. L. KNOPE, AND T. W. QUINN. 2005. Population genetic analysis of Mountain Plover using mitochondrial DNA sequence data. *Condor* 107:353–362.
- PAGE, G. W., J. S. WARRINER, J. C. WARRINER, AND P. W. C. PATON. 1995. Snowy Plover (*Charadrius alexandrinus*). In *The Birds of North America*, no. 154 (A. Poole and F. Gill, Eds.). Academy of Natural Sciences, Philadelphia, and American Ornithologists' Union, Washington, D.C.
- PAGE, R. D. M. 1996. TREEVIEW: An application to display phylogenetic trees on personal computers. *Computer Applications in the Biosciences* 12:357–358.
- PATON, T. A., A. J. BAKER, J. G. GROTH, AND G. F. BARROWCLOUGH. 2003. RAG-1 sequences resolve phylogenetic relationships within Charadriiform birds. *Molecular Phylogenetics and Evolution* 29:268–278.
- PFFENNINGER, M., AND K. SCHWENK. 2007. Cryptic animal species are homogeneously distributed among taxa and biogeographical regions. *BMC Evolutionary Biology* 7:121.
- PRICE, T. 2007. *Speciation in Birds*. Roberts, Greenwood Village, Colorado.
- PRIMMER, C. R., A. P. MØLLER, AND H. ELLEGREN. 1995. Resolving genetic relationships with microsatellite markers: A parentage testing system for the swallow *Hirundo rustica*. *Molecular Ecology* 4:493–498.
- PRIMMER, C. R., J. N. PAINTER, M. T. KOSKINEN, J. U. PALO, AND J. MERILÄ. 2005. Factors affecting avian cross-species microsatellite amplification. *Journal of Avian Biology* 36:348–360.
- PRITCHARD, J. K., M. STEPHENS, AND P. DONNELLY. 2000. Inference of population structure using multilocus genotype data. *Genetics* 155:945–959.
- R DEVELOPMENT CORE TEAM. 2006. R: A language and environment for statistical computing. [Online.] R Development Core Team, Vienna. Available at [www.r-project.org/](http://www.r-project.org/).
- RAYMOND, M., AND F. ROUSSET. 1995. GENEPOP (version 1.2): Population genetics software for exact tests and ecumenicism. *Journal of Heredity* 86:248–249.
- RENSCH, B. 1938. Some problems of geographical variation and species-formation. *Proceedings of the Linnean Society of London* 150:275–285.
- REYNOLDS, J. D. 1996. Animal breeding systems. *Trends in Ecology and Evolution* 11:68–72.
- RICE, W. R. 1989. Analyzing tables of statistical tests. *Evolution* 43:223–225.
- RITTINGHAUS, H. 1961. *Der Seeregenpfeifer*. A. Ziemsen Verlag, Wittenberg, Germany.
- SÁEZ, A. G., AND E. LOZANO. 2005. Body doubles. *Nature* 433:111.
- SCHUG, M. D., S. G. SMITH, A. TOZIER-PEARCE, AND S. F. McEVEY. 2007. The genetic structure of *Drosophila ananassae* populations from Asia, Australia and Samoa. *Genetics* 175:1429–1440.
- SEUTIN, G., B. N. WHITE, AND P. T. BOAG. 1991. Preservation of avian blood and tissue samples for DNA analyses. *Canadian Journal of Zoology* 69:82–90.
- SIBLEY, C. G., AND B. L. MONROE, JR. 1990. *Distribution and Taxonomy of Birds of the World*. Yale University Press, New Haven, Connecticut.
- STROUD, D. A., N. C. DAVIDSON, R. WEST, D. A. SCOTT, L. HAANSTRA, O. THORUP, B. GANTER, AND S. DELANY. 2004. Status of migratory wader populations in Africa and western Eurasia in the 1990s. *International Wader Studies* 15.
- SWOFFORD, D. L. 2000. PAUP\*: Phylogenetic Analysis Using Parsimony (\* and Other Methods). Sinauer Associates, Sunderland, Massachusetts.
- SZÉKELY, T., A. KOSZTOLÁNYI, AND C. KÜPPER. 2008. Practical guide for investigating breeding ecology of Kentish Plover *Charadrius alexandrinus*. University of Bath, Bath, United Kingdom. [Online.] Available at [www.biodiversity-lab.org](http://www.biodiversity-lab.org).
- SZÉKELY, T., AND C. M. LESSELLS. 1993. Mate change by Kentish Plovers *Charadrius alexandrinus*. *Ornis Scandinavica* 24:317–322.
- SZÉKELY, T., AND J. D. REYNOLDS. 1995. Evolutionary transitions in parental care in shorebirds. *Proceedings of the Royal Society of London, Series B* 262:57–64.
- SZÉKELY, T., G. H. THOMAS, AND I. C. CUTHILL. 2006. Sexual conflict, ecology, and breeding systems in shorebirds. *BioScience* 56:801–808.
- SZÉKELY, T., AND T. D. WILLIAMS. 1995. Costs and benefits of brood desertion in female Kentish Plovers, *Charadrius alexandrinus*. *Behavioral Ecology and Sociobiology* 37:155–161.
- THOMAS, G. H., AND T. SZÉKELY. 2005. Evolutionary pathways in shorebird breeding systems: Sexual conflict, parental care, and chick development. *Evolution* 59:2222–2230.
- THOMAS, G. H., T. SZÉKELY, AND J. D. REYNOLDS. 2007. Sexual conflict and the evolution of breeding systems in shorebirds. *Advances in the Study of Behavior* 37:279–342.
- THOMAS, G. H., M. A. WILLS, AND T. SZÉKELY. 2004a. A supertree approach to shorebird phylogeny. *BMC Evolutionary Biology* 4:28.
- THOMAS, G. H., M. A. WILLS, AND T. SZÉKELY. 2004b. Phylogeny of shorebirds, gulls, and alcids (Aves: Charadrii) from the cytochrome-*b* gene: Parsimony, Bayesian inference, minimum evolution, and quartet puzzling. *Molecular Phylogenetics and Evolution* 30:516–526.
- VAN DE KAM, J., B. ENS, T. PIERSMA, AND L. ZWARTS. 2004. *Shorebirds: An Illustrated Behavioural Ecology*. KNNV Publishers, Utrecht, The Netherlands.
- WARRINER, J. S., J. C. WARRINER, G. W. PAGE, AND L. E. STENZEL. 1986. Mating system and reproductive success of a small population of polygamous Snowy Plovers. *Wilson Bulletin* 98:15–37.

Associate Editor: K. T. Scribner

## APPENDIX

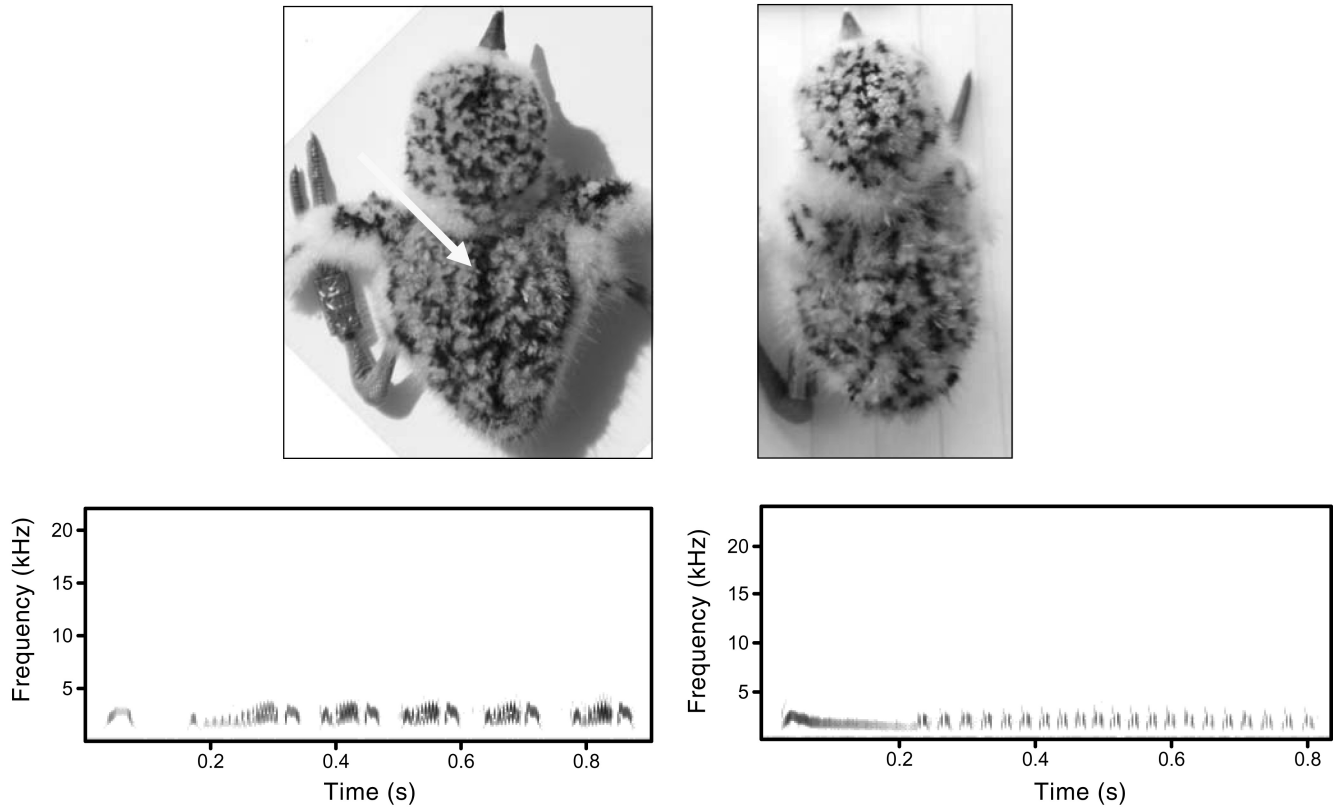

FIG. A1. Phenotypic differences between Kentish and Snowy plovers. Top: Downy chick plumage. Plumage of Kentish Plover chicks (left) features a dark central stripe on the back (indicated by arrow), whereas this stripe is missing in Snowy Plover chicks (right). Both chicks were photographed a few hours after hatching. (Kentish Plover photograph taken by T. Székely in Kujalnik, Ukraine, June 2007. Snowy Plover photograph taken by C. Küpper in Ceuta, Mexico, June 2007.) Bottom: Male courtship calls of Kentish Plovers sampled in France (left) and of Snowy Plovers sampled in North Dakota (right). The pattern is consistent among all transatlantic populations we have sampled. (Snowy Plover calls provided by Lang Elliot. Kentish Plover calls from males breeding in France provided by Jean Roché. Sonograms prepared using SAS LAB LIGHT software [Avisoft Bioacoustics, Berlin]).